

TDA2822M

DUAL LOW-VOLTAGE POWER AMPLIFIER

DESCRIPTION

The TDA2822M is a monolithic integrated circuit in 8 lead Minidip package. It is intended for use as dual audio power amplifier in portable cassette players and radios.

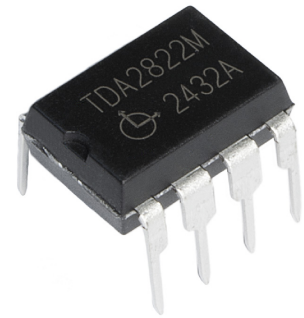

FEATURE

- LOW CROSSOVER DISTORSION
- LOW QUIESCENT CURRENT
- SUPPLY VOLTAGE DOWN TO 1.8V
- BRIDGE OR STEREO CONFIGURATION

PIN CONNECTION

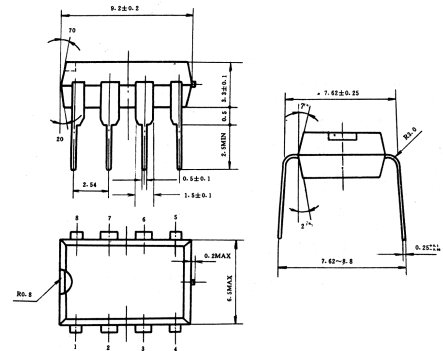
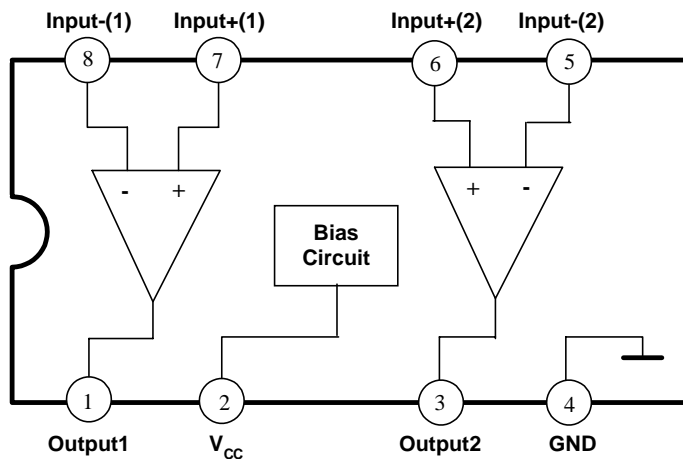

ABSOLUTE MAXIMUM RATINGS (Tamb=25°C, unless otherwise specified)

PARAMETER	SYMBOL	VALUE		UNIT
		MIN.	MAX.	
Supply Voltage	Vcc	-	15	V
Peak Output Current	Io	-	1	A
Power Dissipation	PD	TA =50°C	1	W
		Tcase=50°C	1.4	
Operating Temperature	Tamb	-20	70	°C
Storage and Junction Temperature	Tstag	-40	150	°C

TDA2822M**DUAL LOW-VOLTAGE POWER AMPLIFIER****ELECTRICAL CHARACTERISTICS (Vcc=6V, Tamb=25°C) (STEREO)**

PARAMETER	TEST CONDITIONS	SYMBOL	MIN	TYP	MAX	UNIT
Supply Voltage		Vcc	1.8	-	15	V
Quiescent Output voltage	Vcc=3V	Vo	-	2.7	-	V
			-	1.2	-	V
Quiescent Drain Current		Icc	-	6	9	mA
Input Bias Current		IbA	-	100	-	nA
Output Power	THD=10%, f=1KHz, Vcc=3V	RL=4 Ω	-	110	-	mW
			RL=32 Ω	-	20	
	THD=10% F=1KHz	Vcc=9V RL=8 Ω	-	1	-	W
		Vcc=6V RL=4 Ω	0.4	0.65	-	
Vcc=4.5V RL=4 Ω	-	0.32	-			
Distortion	Po=0.5W, f=1KHz, Vcc=9V, RL=8 Ω	THD	-	0.3	-	%
Closed Loop Voltage Gain	f=1KHz	AvF	-	40	-	dB
Channel Balance		Δ Av	-	-	± 1	dB
Input Resistance	f=1KHz	Ri	100	-	-	K Ω
Total Input Noise	Rs=10K Ω	VNI	-	2	-	μ V
	Rs=10K Ω, B=22Hz~22KHz	-	-	3	-	
Supply Voltage Rejection	f=100Hz C1=C2=100 μ F	Srip	24	30	-	dB
Channel Separation	f=1KHz	CSR	-	50	-	dB

TDA2822M

DUAL LOW-VOLTAGE POWER AMPLIFIER

Test Circuit: (Stereo)

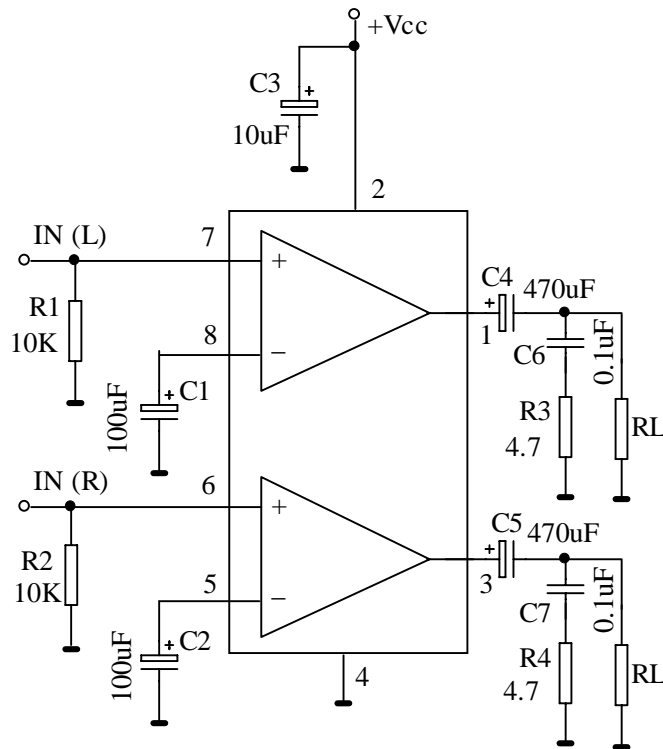

TYPICAL APPLICATION:

1. Application in Portable Players

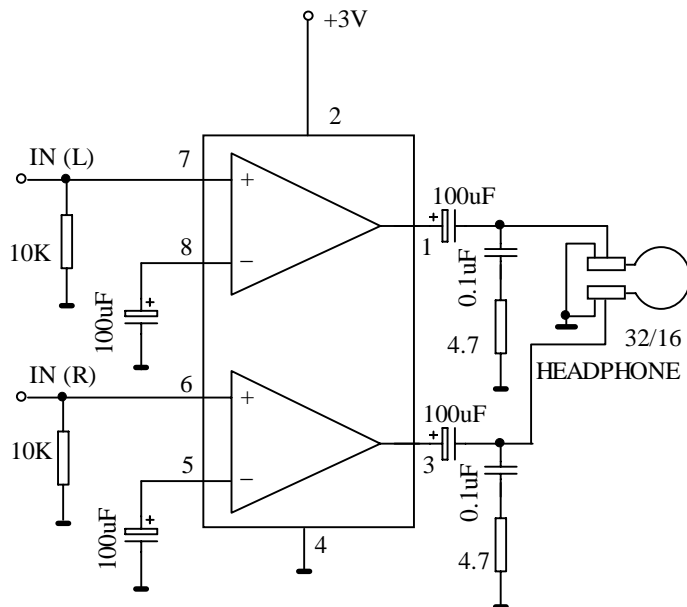

TDA2822M

DUAL LOW-VOLTAGE POWER AMPLIFIER

2. Application in Radio Receivers

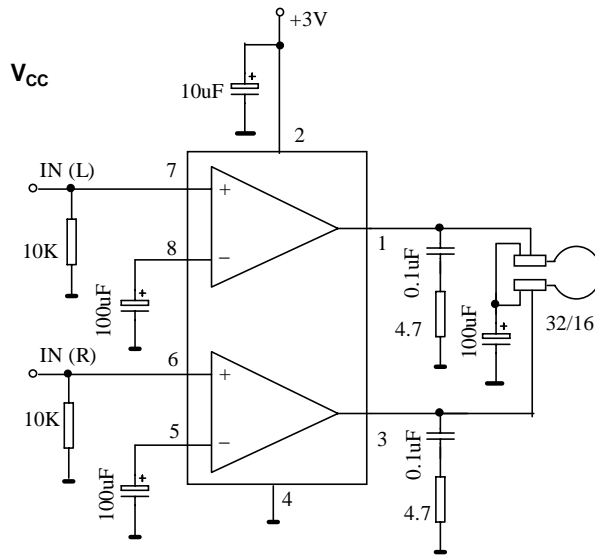

FEATURE DIAGRAM

Fig. 1 - Quiescent current vs. supply voltage

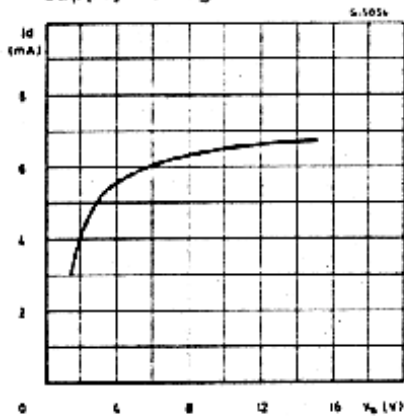

Fig. 2 - Supply voltage rejection vs. frequency (stereo)

