

TYPEC/PD2.0/PD3.0 Physical Layer IC for USB TYPEC input Interfaces

1. Features

- Support TYPEC/PD2.0/PD3.0 UFP mode for USB TYPEC input port
 - Auto-detect USB connection condition
- Integrate USB Power Delivery (PD2.0/PD3.0) protocol
 - Integrate hardware bi-phase Mark Coding (BMC) over CC
 - Integrate physical layer
 - Hardware CRC protect data integrity
 - Integrate PD2.0/PD3.0 protocol UFP engine
 - Support hardreset
- Integrate USB TYPEC protocol
- Power management
 - VBUSG control the power rail by the external NMOS, depending on CC negotiation state
 - IP2721: SEL configure the maximum PD request voltage as 20V, 15V or 5V
 - IP2721_MAX12: SEL configure the maximum PD request voltage as 12V, 9V or 5V
- Support VBUS soft start

- Working voltage: 3V~25V
- Package: TSSOP16

2. Description

IP2721 is a USB TYPEC/PC2.0/PD3.0 physical layer protocol IC for USB TYPEC input port, support auto-detect USB port connection through CC1 and CC2. Integrate hardware PD protocol, analyze PD protocol to get source capabilities and request appropriate voltage accordingly.

3. Typical Applications

- USB TYPEC input port for Power Bank, cell phone, wireless charging dock, VR box and UAV etc.

4. Typical Application Schematic

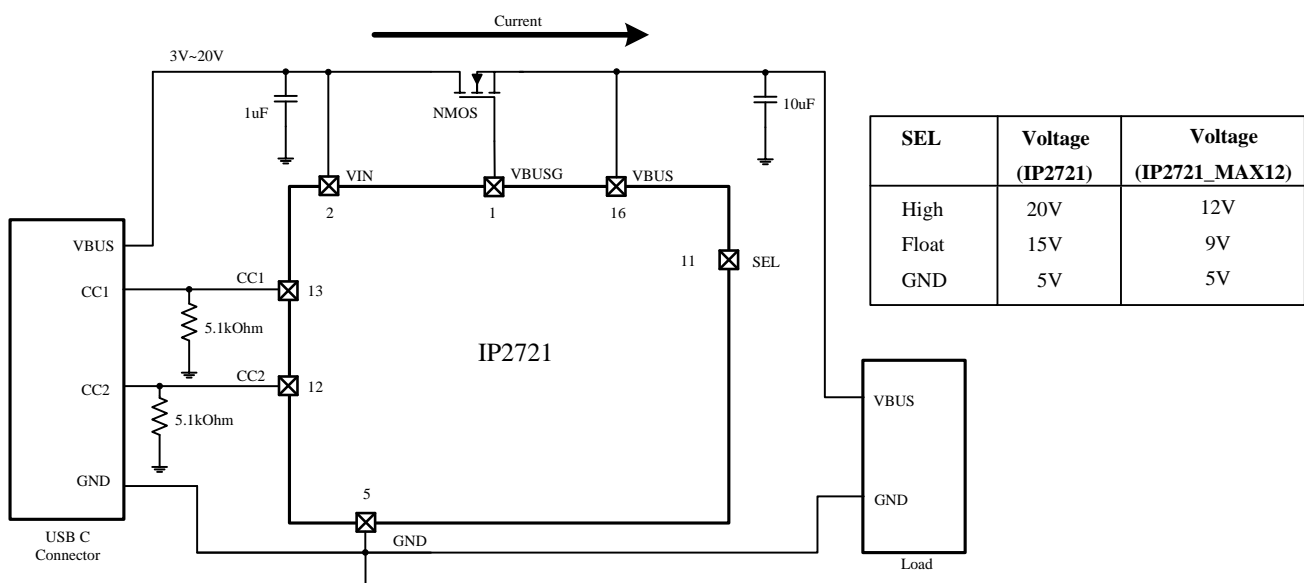

5. PIN Description

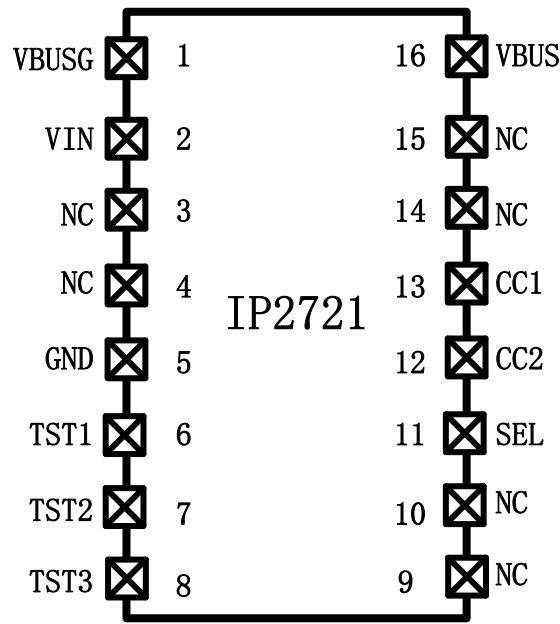

TSSOP16

Pin No.	Pin Name	Description
1	VBUSG	Connect to the gate of external NMOS, in control of the power rail.
2	VIN	Power input pin, apply 1uF capacitor to GND, connect to the Drain of the external NMOS.
3,4	NC	Keep floating
5	GND	Ground
6,7,8	TST1/TST2/TST2	Reserved PIN, keep floating
9,10	NC	Keep floating
11	SEL	IP2721 IP2721_MAX12
		High: 20V 12V
		Floating: 15V 9V
		GND: 5V 5V
12	CC2	Connect to CC2 of USB Type-C port
13	CC1	Connect to CC1 of USB Type-C port
14,15	NC	Keep floating
16	VBUS	Connect to the source of external NMOS

6. IP Series Products List

USB Charging Port Control IC

IC Part No.	Channel	Standards supported										Package	
		BC1.2 & APPLE	QC3.0 & QC2.0	FCP	SCP	AFC	SFCP	MTK PE+ 2.0&1.1	TypeC	NTC	PD2.0/ PD3.0/PPS	Package	Compatibility
IP2110	1	√	-	-	-	-	-	-	-	-	-	SOT23-5	
IP2111 IP2111A	1	√	-	-	-	-	-	-	-	-	-	SOT23-6	
IP2112 IP2112A	2	√	-	-	-	-	-	-	-	-	-	SOT23-6	
IP2161	1	√	√	√	-	√	√	-	-	-	-	SOT23-6	
IP2163	1	√	√	√	-	√	√	√	-	√	-	SOP8	PIN2 PIN
IP2183	1	√	√	√	√	√	√	√	-	-	-	SOP8	
IP2701	1	√	√	√	-	√	√	-	√	-	-	SOP8	
IP2703	1	√	√	√	-	√	√	√	√	√	-	DFN10	
IP2705	1	√	√	√	-	√	√	√	√	√	-	DFN12	
IP2707	2	√	√	√	-	√	√	√	√	√	-	QFN16	
IP2712	1	√	√	√	√	-	-	1.1	√	-	√	TSSOP20L	
IP2716	1	√	√	√	√	√	-	1.1	√	-	√	QFN32	
IP2723	1	√	√	√	√	√	√	√	√	-	√	TSSOP16	
IP2721	1	-	-	-	-	-	-	-	-	-	√ SINK	TSSOP16	

7. Absolute Maximum Ratings

Parameters	Symbol	Value	Unit
VIN input voltage range	VIN	-0.3 ~ 30	V
CC1,CC2 input voltage range	V _{CC1} ,V _{CC2}	-0.3 ~ 30	V
Other pins voltage range		-0.3 ~ 10	V
Junction temperature range	T _J	-40 ~ 150	°C
Storage temperature	T _{stg}	-60 ~ 150	°C
Lead temperature (Soldering, 10sec.)	T _s	260	°C
Ambient temperature range	T _A	-40~120	°C

Package thermal resistance	θ_{JA}	90	°C/W
Package thermal resistance	θ_{JC}	39	°C/W
Human body model (HBM)	ESD	2	KV

*Stresses beyond those listed under Absolute Maximum Ratings may cause permanent damage to the device.

Exposure to Absolute Maximum Rated conditions for extended periods may affect device reliability.

*Voltages are referenced to GND unless otherwise noted.

8. Recommended Operating Conditions

Parameter	Symbol	Min.	Typ.	Max.	Unit
Input voltage	V _{IN}	3		25	V
Ambient temperature	T _A	-40		85	°C

*Devices' performance cannot be guaranteed when working beyond those Recommended Operating Conditions.

9. Electrical Characteristics

Unless otherwise specified, T_A = 25 °C, 4.5V ≤ V_{CC1} ≤ 5.5V

Parameter	Symbol	Test Condition	Min.	Typ.	Max.	Unit
Input voltage	V _{IN}	Supplied directly	3		25	V
Input UVLO threshold	UVLO	V _{IN} Falling	2.5		2.9	V
Quiescent current	I _Q	CC floating	120		145	uA
		CC connected	1		1.5	mA
Start time	T _S		20	37	50	us
V _{BUS} soft start time	T _V		3.5		4.5	ms
SEL input high voltage threshold	V _{SELH}		2.5			V
SEL input low voltage threshold	V _{SELL}				0.3	V
SEL default output voltage	V _{SELO}		1.35	1.5	1.65	V
CC1/CC2 connection detection threshold voltage	V _{CC1_TH} / V _{CC2_TH}		0.25		2.04	V

10. Function Description

USB TYPEC/PD protocol

IP2721 is an integrated USB TYPEC PD protocol IC for USB input port, support USB TYPEC/PD2.0/PD3.0 protocol. USB TYPEC device plug-in and plug-out is auto-detected based on CC1/CC2 pins. IP2721 integrated PD protocol analyzer to get the voltage capabilities and request the matched voltage.

- Port mode: sink (device)
- Auto-detect USB TYPEC device plug-in and plug-out
- Integrate hardware bi-phase Mark Coding (BMC) over CC
- Integrate physical layer
- Integrate PD protocol state machine
- Support PD hardreset

SEL pin

SEL pin is used to configure the maximum voltage that IP2721 will request, when SEL is pulled to high voltage level V_{SELH} , the maximum request voltage is 20V; when SEL is floating, the maximum voltage that IP2721 request is 15V; when SEL pull down to GND, IP2721 only request 5V voltage.

If the maximum voltage SRC port supported is lower than IP2721 capable of, IP2721 will request the maximum voltage supported by the SRC port. If the maximum voltage SRC port supported is higher than IP2721 capable of, IP2721 will request its maximum voltage and supported by the SRC port as well. That is to say, IP2721 will request the maximum voltage supported by both IP2721 and SRC port.

The customized models of IP2721_MAX is configured switching the maximum request voltage among 12V, 9V and 5V by SEL. SEL pull 100kohm resistor to VIN is V_{SELH} . The switching of SEL voltage level is not supported after power up, it should be connected well before IP2721 power up.

SEL	IP2721 Voltage	IP2721_MAX12 Voltage
V_{SELH}	20V	12V
Floating	15V	9V
GND	5V	5V

Power path control

IP2721 support external NMOS for power path control, controlling the Gate of external NMOS by VBUSG pin. The NMOS will be turned on when CC connection is established, and turned off when CC disconnected.

*Power NMOS of Vds withstand voltage above 30V is recommended.

11. Package

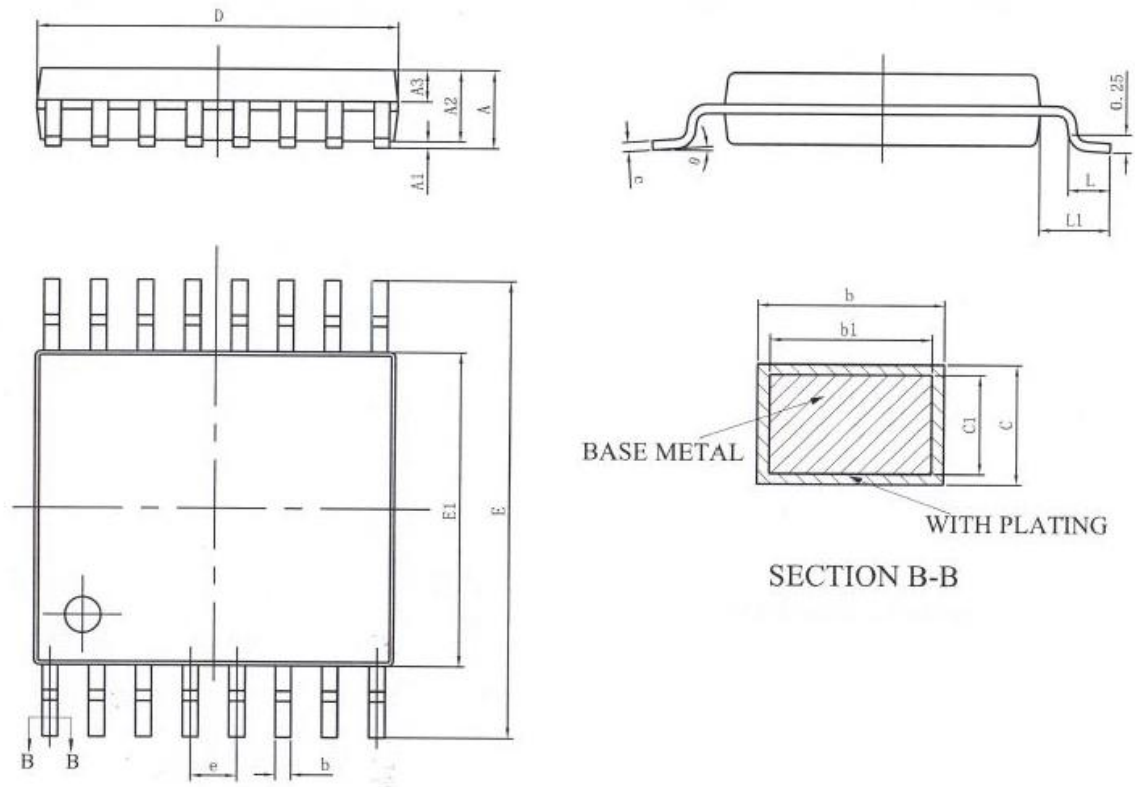

SYMBOL	MILLIMETER		
	MIN	NOM	MAX
A	—	—	1.20
A1	0.05	—	0.15
A2	0.90	1.00	1.05
A3	0.39	0.44	0.49
b	0.20	—	0.29
b1	0.19	0.22	0.25
c	0.13	—	0.18
c1	0.12	0.13	0.14
D	4.86	4.96	5.06
E	6.20	6.40	6.60
E1	4.30	4.40	4.50
e	0.65BSC		
L	0.45	0.60	0.75
L1	1.00BSC		
θ	0	—	8°