

# KA2284

# LINEAR INTEGRATED CIRCUIT

## 5-DOT DUAL LED LEVEL METER DRIVER

### DESCRIPTION

The KA2284 is a monolithic integrated circuit designed for 5-dot LED level meter drivers with a built-in rectifying amplifier. It is suitable for AC/DC level meters such as VU meters or signal meters.

### FEATURES

- \*High gain rectifying amplifier included( $G_v=26\text{dB}$ )
- \*Low radiation noise when LED turns on
- \*logarithmic indicator for 5-dot LED of bar type.
- \*Constant current output( 15mA)
- \*Wide operating supply voltage(3.5V~16V)
- \*Not necessary diode or transistor for ALC
- \*Minimum number of external parts required

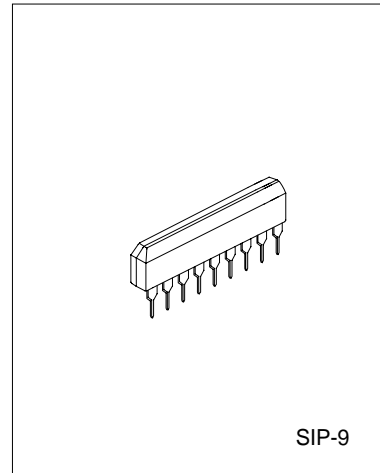

### BLOCK DIAGRAM

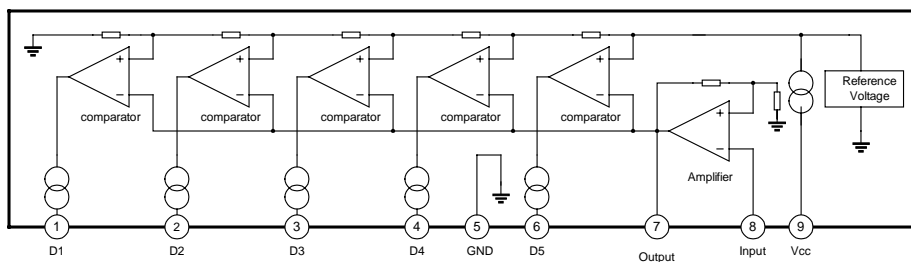

### ABSOLUTE MAXIMUM RATINGS ( $T_a=25^\circ\text{C}$ )

Characteristic	Symbol	Value	Unit
Supply Voltage	Vcc	16	V
Amplifier input Voltage	V8	-0.5V~Vcc	V
Pin 7 Voltage	V7	6	V
D terminal Output Voltage	V <sub>D</sub>	16	V
Operating Temperature	T <sub>opr</sub>	-20 to +80	°C
Storage Temperature	T <sub>stg</sub>	-40 to 125	°C
Power dissipation	P <sub>D</sub>	1100	W

**ELECTRICAL CHARACTERISTICS** ( $T_a=25^\circ\text{C}$ ,  $T_c=25^\circ\text{C}$ ,  $V_{CC}=6\text{V}$ ,  $f=1\text{kHz}$ , unless otherwise specified)

Characteristic	Symbol	Test Condition	Min	Typ.	Max	Unit
Supply Voltage	$V_{CC}$		3.5	6.0	16.0	V
Supply Current	$I_{CC}$	$V_{IN}=0$		5	8	mA
Sensitivity	$V_{in}$	In $V_{C3}$ Level	46	56	66	mV
Comparator ON Level 1	$V_{C1}$		-11.5	-10.0	-8.5	dB
Comparator ON Level 2	$V_{C2}$		-6	-5	-4	dB
Comparator ON Level 3	$V_{C3}$			0		dB
Comparator ON Level 4	$V_{C4}$		2.5	3.0	3.5	dB
Comparator ON Level 5	$V_{C5}$		5	6	7	dB
LED Output current	$I_{LED}$		11.0	15.0	18.5	mA
Amp Gain	$G_v$	$V_i=0.1\text{V}$	24	26	28	dB
Input Bias Current	$I_{NO}$		-1.0	-0.3		$\mu\text{A}$

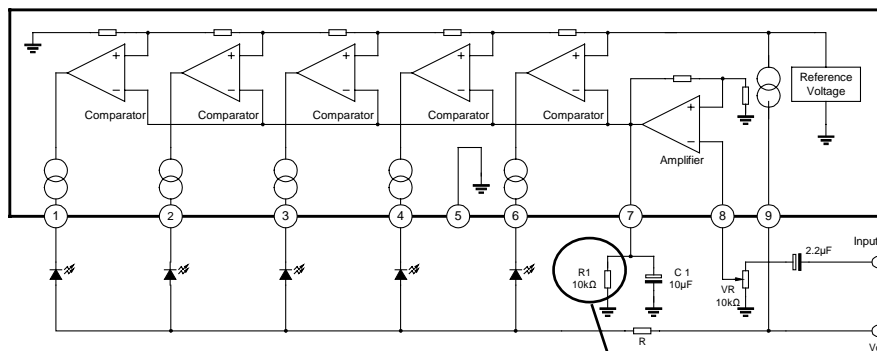
**TEST CIRCUIT**

调节此电阻（1K欧姆左右）可调整点灯灵敏度

## APPLICATION INFORMATION

1. By changing the time constant C1 and ,the response, attack and release time, may be varied. In the above application conditions, power dissipation may be operated at higher levels than the absolute maximum ratings. The wattage of R is to be determined by the total LED current and R value recommended by the R table.

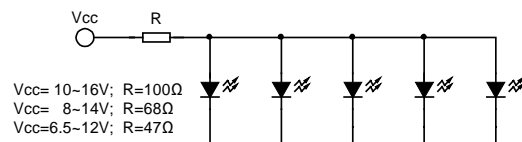

TO KA2284

## TYPICAL PERFORMANCE CHARACTERISTICS

