

■ **General Description**

A3144E is a switched Hall-Effect IC, which is for contactless switching applications. The device includes an on-chip Hall voltage generator for magnetic sensing, an amplifier that amplifies the Hall voltage, a Schmitt trigger to provide switching hysteresis for noise rejection, and an open-collector output. The bandgap regulator allows a wide operating voltage range. A3144E is rated for operating temperature range from -40°C to 150°C and voltage range from 3.8V to 40V. A3144E are capable of continuous 20mA sinking out and maybe cycled as high as 50mA maximum.

■ **Features**

- High temp Unipolar Hall Effect Switch Sensor
- Wide operating voltage range: 3.8V~40V
- Open Collector Pre-Driver
- Maximum output sink current: 50mA
- Chip Power Reverse-Connection Protection
- Operating Temperature: -40°C~+150°C
- Small Size Package: SIP3L

■ **Applications**

- Non-Contact Switch
- Automotive Ignition
- Braker ICs
- Position Control
- Revolution Detection
- Safe Alarm Device
- Textile Control System

■ **Ordering Information**

PART NUMBER	TEMPERATURE RANGE	PACKAGE	TAPE & REEL
A3144EUA	-40°C to 150°C	SIP3	-T

■ **Pin Configuration**

(Top View)

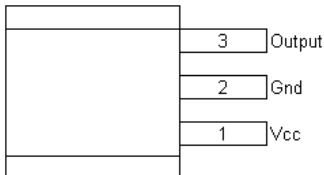

Name	No.	Status	Description
Vcc	1	P	Input Power Supply
Gnd	2	P	Ground
Output	3	O	Output Stage of Open Collector

■ **Functional Block Diagram**

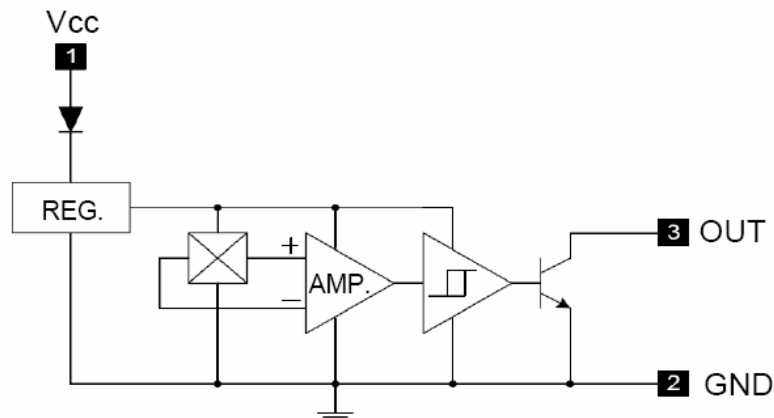

■ **Absolute Maximum Ratings**

Parameter	Symbol	Rating
Supply Voltage	VCC	-40 V to +40VDC
Voltage externally applied to output	Vout (off)	+40 VDC max, OFF condition only -0.5 V min., OFF or ON condition
Output "ON" Current	Io (sink)	50 mA
Power Dissipation	PD	450mW (SIP3L)
Operation Temperature Range	Top	-40 to +150°C
Storage Temperature Range	Tst	-65 to +150°C
Magnetic Flux	B	No limit.

Note : Absolute Maximum Rating are those values beyond which the life of a device may be impaired.

■ **Electrical Characteristics(Ta=25°C)**

Symbol	Parameter	CONDITIONS	MIN.	TYP.	MAX.	UNIT
Vcc	Supply Voltage	Operating	3.8		30	V
VO (SAT)	Output Saturation Voltage	Vcc = 12V, OUT "ON", Io = 20mA	-		400	mV
		Vcc = 24V, OUT "ON", Io = 20mA			400	mV
Icc	Supply Current	Vcc = 4.5V~24V, OUT "OFF"	-	4	10	mA
I <sub>LE</sub>	Output Leakage Current (Leakage into sensor output)	Released	-		10	μA
Tr	Output Switching Time	Rise Time		0.2		μS
Tf		Fall Time	RL=820Ω, CL=20pF		0.5	

■ **Magnetic Characteristics(Ta=25°C, Vcc=3.8~30V)**

Symbol	Parameter	MIN.	TYP.	MAX.	UNIT
Bop	Operation Point	90		230	Gauss
Brp	Release Point	70		200	Gauss
Bhy	Hysteresis	20	50	80	Gauss

■ **Operating Characteristics**

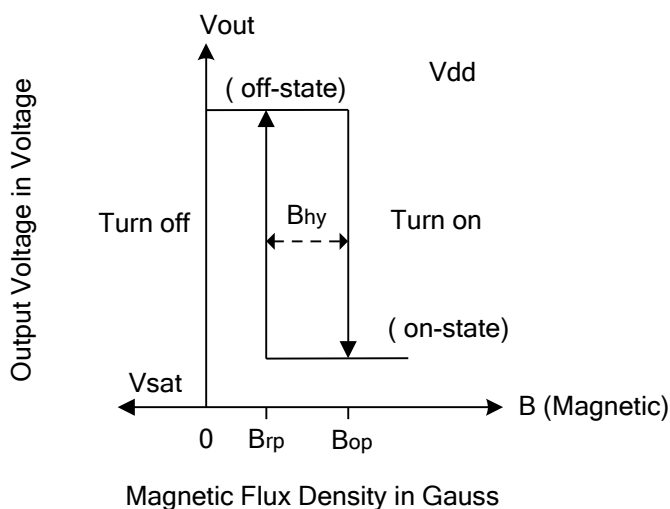
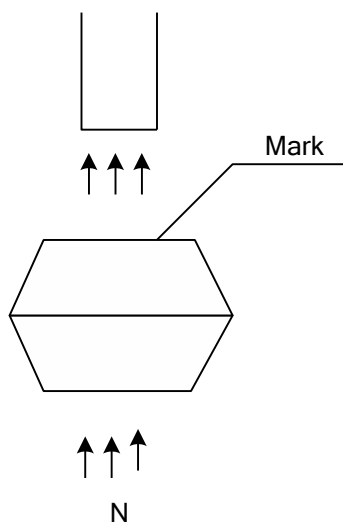

■ **Test Circuits**

3144E

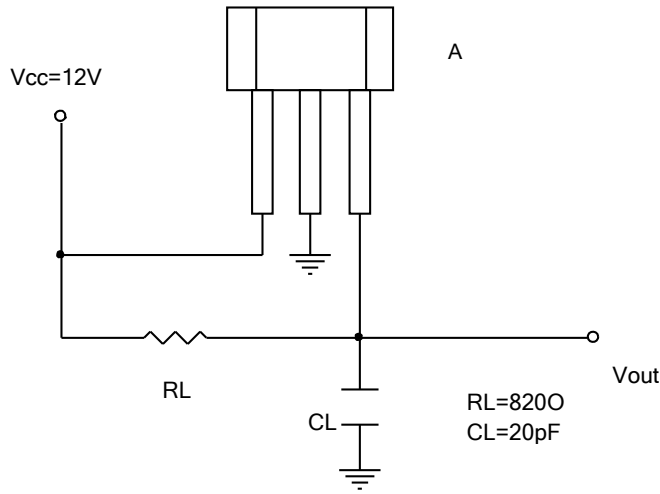

**Fig1**

■ **Hall Sensor Location**

The Fig2 is hall sensor location, where marks the IC number.

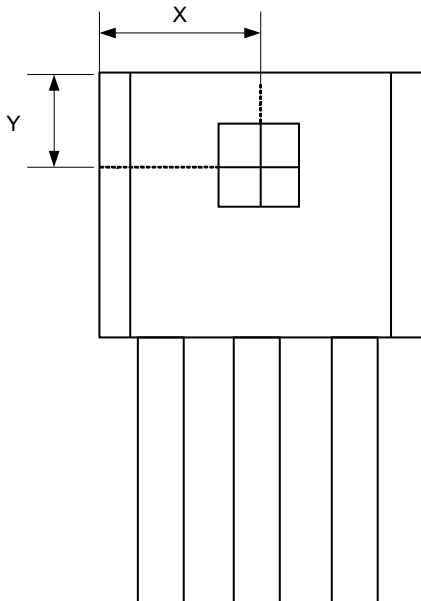

		Unit
X	2.00	mm
Y	1.15	mm

**Fig2 A3144E Hall Sensor Location**

■ **Package Information**

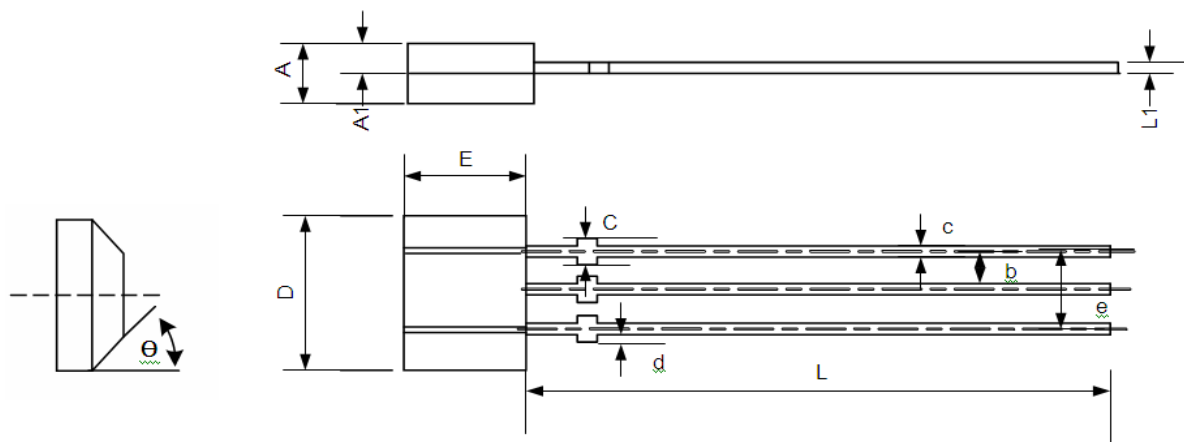

Symbol	Dimensions In Millimeters		Dimensions In Inches	
	Min.	Max.	Min.	Max.
A	1.245	1.753	0.049	0.069
A1	0.750REF		0.030REF	
b	1.270REF		0.050REF	
C	0.406	0.508	0.016	0.020
c	0.330	0.432	0.013	0.017
D	3.960REF		0.156REF	
d		0.100		0.004
E	2.870	3.124	0.113	0.123
e	2.540REF		0.100REF	
L	13.60	15.60	0.535	0.614
L1	0.350	0.410	0.014	0.016
θ		45°		45°

■ **Packing Information**

1. Packing type: Box
2. Packing minimum: 1000pcs

**Note:** PowerSilicon corporation assumes no responsibility for any errors which may appear in this document. PowerSilicon corporation reserves the right to change devices or specifications detailed herein at any time without notice.